

**SUZHOU DAZEN ELECTROMECHANICAL TECHNOLOGY CO., LTD**

Add: No.39,Qihong Road , Suzhou Industrial Park, Suzhou, Jiangsu , China

Fenyang Road ,FenHu Industry Zone,Wujiang,Suzhou,China

Tel: 86-512-67604536

Fax: 86-512-67604536

Email: [info@dazenelevator.com](mailto:info@dazenelevator.com)

<https://www.dazenelevator.com>



**Premium Elevator  
Brand**

**DAZEN**  
SAFE ARRIVAL



## MASSIVE PRODUCTION

Suzhou Dazen Electromechanical Technology Co., Ltd is using the first-class production equipment, including CNC cutting machine, CNC bending machine, CNC turret punch and other full set of CNC machining equipments. The division of labor in each workshop is clear, the process is rigorous, so that we can achieve our large scale, high efficiency and high quality production. Advanced production technology and standard work flow ensure Dazen can provide the perfect quality.



## COMPANY PROFILE

Suzhou Dazen Electromechanical Technology Co., Ltd was established based on an elevator company, who is an elevator and elevator parts full solution provider. We own a stronger research and technical team from Otis, Kone also manufacture with 6m/s high speed testing tower and more than 5000 sets of elevator production capacity, making us not only able to provide high competitive elevators and parts, but also provide the most strength protection for elevator safety.

Powerful production system and technical team makes us build a complete product series which includes Passenger elevator, Home elevator, Cargo elevator, Hospital elevator, Glass Elevator, escalator and all kinds of Elevator components. We take quality management as the foundation of the enterprise. Our products are qualified with ISO9001-2000, ISO14000, CE certification etc. Powerful service network and installation team makes us build relationships with customers from Europe, Middle East, South America, South East Asia. And also we finished lots of projects both in domestic and overseas.

Dazen elevator's mission is not only focus on to be the best elevator solution provider, also willing to be the best technical support provider and marketing guide, create future together hand by hand with customer.

# PREMIUM ELEVATOR BRAND IS ALL ABOUT PERFECT DETAILS

A Strong And Quality Brand Is All About Perfect Details, All Details About Quality,technology,customer. Dazen Take Care Of All Details, Create Most Competitive Elevator And Escalator.

Perfect Technical Team with Perfect Service

DAZEN Own the best team from Otis With Rich experience,not only give you best solution in time,but also a teacher help you grow up.

Advanced ERP Production System With Perfect Quality Control

More than 10 step for quality Inspection,and advanced production system ensure DAZEN facing Zero quality complain and Zero Missing Spare Parts.



# Advanced System With Top Brand Technology



## Japan Technology Door

The use of digital VVVF variable voltage inverter drive, high-performance space vector control technology, with 32-bit digital signal controller, so that elevator operation more stable and efficient, safe and reliable.

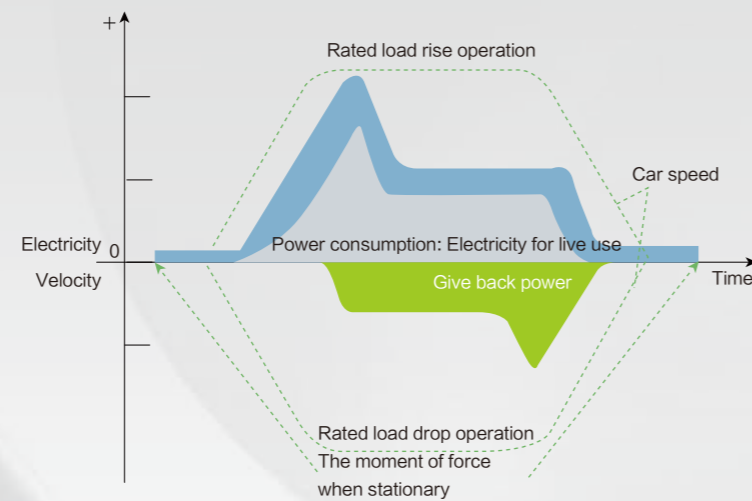

## Germany Permanent Magnet Gearless Traction Machine

High-precision permanent magnetic synchronous positioning technology combined with automated centralized winding motor, more efficient, low energy consumption, real green energy saving.

VVVF inverter control system  
RoHS-compliant, lower operating noise, high harmonics with suppressed power supply, long design life.



## Stable intellectual control system

Adopt high integration, double 32-bit S intelligent full-computer control system, make elevator data processing faster, and the classic combination of a dedicated full-digital vector IP inverter, through the full closed-loop speed feedback adjustment, so that the elevator operation is extremely long and smooth. And comfortable operation.

## Energy feedback technology

Based on the high energy-saving energy feedback technology controlled by dual PWM, the renewable green energy and non-polluting energy consumption by the energy resistance can be fed back to other electrical equipment, which is more than 30% energy saving on average compared to ordinary VVVF elevators. Fully meet the relevant national power quality standards.

# Full-plan Provider Of Public Traffic Service

We focus upon the elevator field. We offer the best vertical transport solution plan. Let's experience a completely new longing which integrates practical, artistic and contemporary properties into one. We try our best to deduct a classical brand of Chinese elevators.

## Passenger Elevator

We satisfy the clients' requirements by the accurate, effective, flexible, rational, systematic control. It is widely applicable for residence, office building, hotel, traffic hub, shopping center, public building etc.



## Hospital Elevator

Multiple safety designs effectively reduce any accidents. Therefore, the disabled patients can safely enter into/exit from the hospital etc. It is applicable for the hospitals.

Multiple door open modes



# Lift Weights Lightly And Carry Them Easily

Super capacity of vertical space transportation  
handle complicated matters with ease  
Building a free passage for bulk goods  
DAZEN freight elevator series products with excellent  
quality, reliable technology  
Bring unlimited possibilities for cargo transportation in  
vertical space

## Freight Elevator

Relying on the outstanding travel performance, it is competent to various transport takes under various  
harsh conditions. It is widely applicable for office building, hotel, traffic hub, shopping center, factory etc.

## Glass Elevator

It fulfills a most attractive vision by the transparent car design. It fully sets forth  
beauty in modern cities. It is widely applicable for the hotel, shopping  
center, public building and so on.

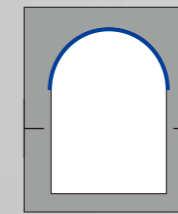

Semi-circular shaped

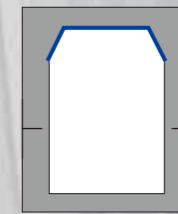

Cutting-angle-type

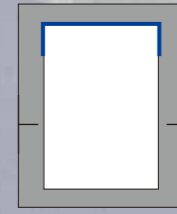

Square shaped

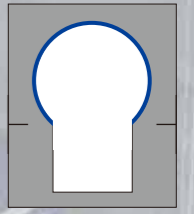

Future prospects



Graphic blue line part shows observation face transparent glass.

# Meet The Demand Of Diversification Of Family



**SMOOTH  
OPERATION**



**NOISE  
REDUCING**



**ECONOMIC  
ATTRACTIVE**

## Villa Elevator

It is exclusively designed for personal space, to create harmonious and comfortable lives. As one of the important components of the family, the home elevator creates the quality experience where the floor space are interacted, and makes the whole villa space designed appropriately. The home elevator meets the perfect need of connecting the up and down space closely, making family space warm, harmonious, comfortable and convenient.



# Passenger Cabin Decor



**DZ-N01**

Ceiling: Central image arch, stainless steel bottom panel is supplemented with soft lighting design of down lamp on both sides  
 Stainless Steel Hairline : Mirror, etched, hairline  
 Handrail: Stainless steel tube handrail  
 Floor: PVC/Marble



**DZ-N02**

Ceiling: Central image arch, stainless steel bottom panel is supplemented with soft lighting design of down lamp on both sides  
 Car wall: Mirror, etched, hairline  
 Handrail: Stainless steel tube handrail  
 Floor: PVC/Marble



**DZ-N05**

Ceiling: Central image arch, stainless steel bottom panel is supplemented with soft lighting design of down lamp on both sides  
 Car wall: Mirror, Golden etched, hairline  
 Handrail: Golden Stainless steel tube handrail  
 Floor: PVC/Marble



**DZ-N06**

Ceiling: Central image arch, stainless steel bottom panel is supplemented with soft lighting design of down lamp on both sides  
 Car wall: Mirror, Golden Etched, hairline  
 Handrail: Golden Stainless steel tube handrail  
 Floor: PVC/Marble



**DZ-N03**

Ceiling :Mirror Stainless Steel ,acrylic lighting, LED  
 Car wall: Etched mirror stainless steel,  
 Handrail: stainless steel round handrail  
 Floor: PVC/Marble



**DZ-N04**

Ceiling: Central image arch, stainless steel bottom panel is supplemented with soft lighting design of down lamp on both sides  
 Car wall: Mirror, etched, hairline  
 Handrail: Stainless steel tube handrail  
 Floor: PVC/Marble



**DZ-N07**

Ceiling:Painted steel plate frame,acrylic transparent board,LED  
 Car wall:Bronze mirror stainless steel sandblasting  
 Floor:PVC/Marble



**DZ-N08**

Ceiling: rose gold, stainless steel, acrylic lighting  
 Car wall: rose gold stainless steel, rose gold mirror etched stainless steel  
 Handrail: stainless steel pipe round handrail  
 Floor: PVC/Marble



# Passenger Cabin Decor



## DZ-R01

Ceiling: Hairline stainless steel, tube light  
Rear wall: Hairline stainless steel  
Side wall: Hairline stainless steel  
Floor: PVC/Marble



## DZ-R02

Ceiling: Hairline stainless steel, tube light  
Rear wall: Wood grain cosmetic steel plate  
Side wall: wood grain cosmetic steel plate, hairline stainless steel  
Floor: PVC/Marble



# Passenger Cabin Decor



## DZ-R03

Ceiling: Hairline stainless steel, acrylic lighting, tube light  
 Rear wall: Hairline stainless steel  
 Side wall: Hairline stainless steel  
 Floor: PVC/Marble



## DZ-K01

Ceiling: Hairline stainless steel, acrylic lighting, tube light  
 Rear wall: Mirror etched stainless steel, hairline stainless steel  
 Side wall: Hairline stainless steel  
 Floor: PVC/Marble



## DZ-K02

Ceiling: Mirror stainless steel, acrylic lighting, tube light  
 Rear wall: Mirror etched stainless steel, mirror stainless steel  
 Side wall: Mirror etched stainless steel, mirror stainless steel  
 Floor: PVC/Marble



## DZ-R04

Ceiling: Hairline stainless steel, tube light  
 Rear wall: Hairline stainless steel  
 Side wall: Hairline stainless steel  
 Floor: PVC/Marble



## DZ-K03

Ceiling: Hairline stainless steel, acrylic lighting  
 Rear wall: Mirror etched stainless steel, hairline stainless steel  
 Side Wall: Hairline stainless steel, mirror stainless steel  
 Floor: PVC/Marble



## DZ-K04

Ceiling: Mirror stainless steel, acrylic lighting, tube light  
 Rear wall: Mirror etched stainless steel, hairline stainless steel  
 Side wall: Mirror etched stainless steel, hairline stainless steel  
 Floor: PVC/Marble



# Passenger Cabin Decor



**DZ-K05**

Ceiling: Mirror stainless steel, acrylic lighting, tube light  
 Rear wall: Mirror etched stainless steel, mirror stainless steel  
 Side wall: Mirror stainless steel, hairline stainless steel  
 Floor: PVC/Marble



**DZ-K06**

Ceiling: Mirror stainless steel, hairline stainless steel, acrylic lighting, tube light  
 Rear wall: Mirror etched stainless steel, mirror stainless steel  
 Side wall: Mirror etched stainless steel, mirror stainless steel  
 Floor: PVC/Marble



**DZ-K09**

Ceiling: Rose gold mirror stainless steel, acrylic lighting, tube light  
 Rear wall: Rose gold mirror etched stainless steel, Rose gold mirror stainless steel  
 Side Wall: Rose gold mirror etched stainless steel, rose gold mirror stainless steel  
 Floor: PVC/Marble



**DZ-K10**

Ceiling: Rose gold mirror stainless steel, acrylic lighting  
 Rear wall: Rose gold mirror stainless steel  
 Side wall: Mirror etched stainless steel, mirror stainless steel  
 Floor: PVC/Marble



**DZ-K07**

Ceiling: Mirror stainless steel, acrylic lighting, tube light  
 Rear wall: Mirror etched stainless steel, gray titanium hairline stainless steel  
 Side Wall: Grey titanium hairline stainless steel, mirror stainless steel  
 Floor: PVC/Marble



**DZ-K08**

Ceiling: Mirror stainless steel, acrylic lighting, tube light  
 Rear wall: Mirror etched stainless steel, hairline stainless steel  
 Side wall: Mirror etched stainless steel, hairline stainless steel  
 Floor: PVC/Marble



**DZ-K11**

Ceiling: Rose gold mirror stainless steel, tube light, light strip  
 Rear wall: Rose gold mirror etched stainless steel, rose gold patterned stainless steel  
 Side Wall: Rose gold mirror stainless steel, rose gold pattern stainless steel  
 Floor: PVC/Marble



**DZ-K12**

Ceiling: Rose gold mirror stainless steel, acrylic lighting  
 Rear wall: Rose gold mirror etched stainless steel, Rose gold mirror stainless steel  
 Side Wall: Rose gold mirror stainless steel, rose gold pattern stainless steel  
 Floor: PVC/Marble

# Passenger Cabin Decor



**DZ-K13**

Ceiling: Rose gold patterned stainless steel, acrylic lighting  
 Rear wall: Mirror etched stainless steel, rose gold patterned stainless steel  
 Side wall: Mirror stainless steel, rose gold patterned stainless steel  
 Floor: PVC/Marble



**DZ-K14**

Ceiling: Hairline stainless steel, acrylic lighting  
 Rear wall: Leather hard package, mirror stainless steel inlay, antique bronze hairline stainless steel  
 Side wall: Mirror stainless steel, antique bronze hairline stainless steel  
 Floor: PVC/Marble



**DZ-K17**

Ceiling: Mirror stainless steel, black titanium mirror stainless steel, light strip  
 Rear wall: Hairline stainless steel, black titanium mirror stainless steel, light strip  
 Side Wall: Hairline stainless steel, black titanium mirror stainless steel  
 Floor: PVC/Marble

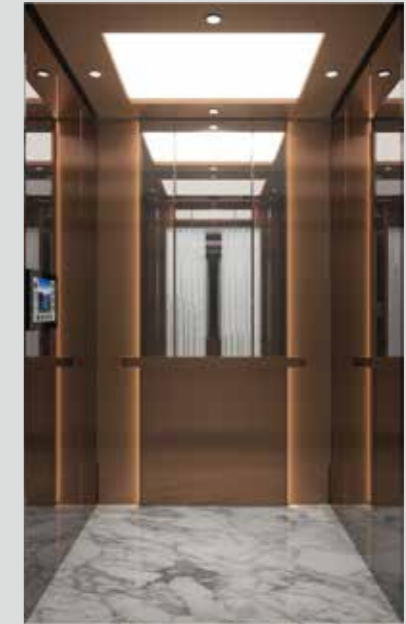

**DZ-K18**

Ceiling: Antique bronze, stainless steel with hair patterns, acrylic lighting, tube lights  
 Rear wall: Antique bronze mirror stainless steel, light strip, antique bronze hairline stainless steel  
 Side wall: Antique bronze mirror stainless steel  
 Floor: PVC/Marble



**DZ-K15**

Ceiling: Painted steel plate, tube light, light strip  
 Rear wall: Rose gold mirror etched stainless steel, Rose gold mirror stainless steel  
 Side wall: Rose gold patterned stainless steel, mirror stainless steel inlay strip  
 Floor: PVC/Marble



**DZ-K16**

Ceiling: Rose gold mirror stainless steel, acrylic lighting  
 Rear wall: Rose gold mirror etched stainless steel  
 Side wall: Rose gold mirror etched stainless steel, rose gold patterned stainless steel  
 Floor: PVC/Marble



**DZ-K19**

Ceiling: Painted steel plate, tube light, light strip  
 Rear wall: Mirror stainless steel, rose gold patterned stainless steel, light strip  
 Side wall: Mirror stainless steel, rose gold patterned stainless steel  
 Floor: PVC/Marble



**DZ-K20**

Ceiling: Antique copper mirror stainless steel, acrylic lighting  
 Rear wall: Antique bronze mirror stainless steel, antique bronze hairline stainless steel  
 Side wall: Antique copper mirror stainless steel inlay, antique copper hairline stainless steel  
 Floor: PVC/Marble

# Panoramic Cabin Decor



**DZ-K21**

Ceiling: Mirror stainless steel, tube light  
 Rear wall: Aluminum alloy frame, safety glass  
 Side wall: Aluminum alloy frame, safety glass, black titanium mirror stainless steel  
 Floor: PVC/Marble



**DZ-K22**

Ceiling: Black titanium mirror stainless steel, acrylic lighting  
 Rear wall: Black titanium aluminum alloy, safety glass, light strip  
 Side wall: Black titanium aluminum alloy, safety glass  
 Floor: PVC/Marble



**DZ-K25**

Ceiling: Mirror stainless steel, light strip  
 Rear wall: Aluminum alloy, rock slab  
 Side wall: Aluminum alloy, safety glass  
 Floor: PVC/Marble



**DZ-K26**

Ceiling: Black titanium mirror stainless steel, acrylic lighting, safety glass  
 Rear wall: Black titanium aluminum alloy, safety glass  
 Side wall: Black titanium aluminum alloy, safety glass  
 Floor: PVC/Marble



**DZ-K23**

Ceiling: Rose gold patterned stainless steel, acrylic lighting  
 Rear wall: Rose gold aluminum alloy, safety glass  
 Side Wall: Rose gold aluminum alloy, safety glass  
 Floor: PVC/Marble



**DZ-K24**

Ceiling: Rose gold patterned stainless steel, acrylic lighting, tube light  
 Rear wall: Rose gold aluminum alloy, safety glass  
 Side Wall: Rose gold aluminum alloy, safety glass  
 Floor: PVC/Marble



**DZ-K27**

Upper and lower covers: Hairline stainless steel, light strip  
 Ceiling: Hairline stainless steel, acrylic lighting, tube light  
 Rear wall: Hairline stainless steel, safety glass  
 Side wall: Hairline stainless steel, safety glass  
 Floor: PVC/Marble



**DZ-K28**

Upper and lower covers: Titanium gold patterned stainless steel, decorative lighting  
 Ceiling: Titanium mirror stainless steel, acrylic lighting, tube light  
 Rear wall: Titanium mirror stainless steel, safety glass  
 Side wall: Titanium mirror stainless steel, safety glass  
 Floor: PVC/Marble

# Car Operation Panel



## Display screen

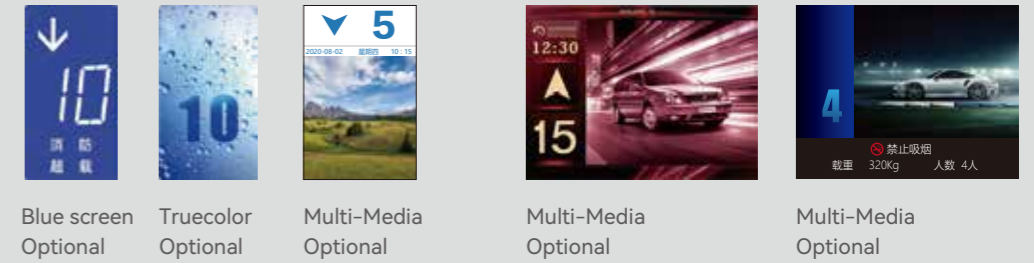

Multimedia display size: 7 inch, 8.4 inch, 10.4 inch

## Button (optional)



## Button (optional)



## Horizontal hall display (optional)

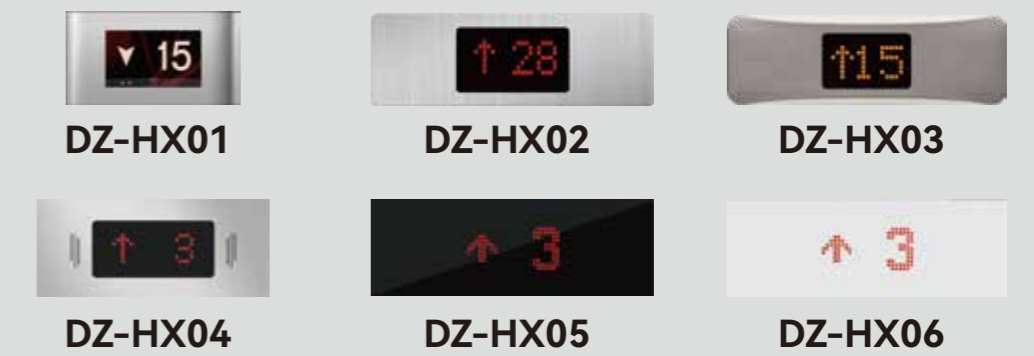

# Landing Door



DZ-M01



DZ-M02



DZ-M05



DZ-M06



DZ-M03



DZ-M04



DZ-M07



DZ-M08

# Landing Door



DZ-M09



DZ-M10



DZ-M11



DZ-M12

# Ceiling Series



DZ-D01



DZ-D02



DZ-D03



DZ-D04



DZ-D05



DZ-D06

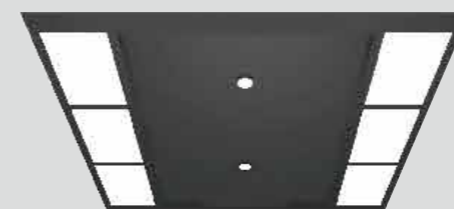

DZ-D07



DZ-D08



# Ceiling Series



DZ-JD01



DZ-JD02



DZ-JD03



DZ-JD04



DZ-JD05



DZ-JD06



DZ-JD07



DZ-JD08



DZ-JD09



DZ-JD10



DZ-JD11



DZ-JD12



DZ-JD13

# Handrail Series



DZ-F01



DZ-F02



DZ-F03



DZ-F04



DZ-F05



DZ-F06



DZ-F07

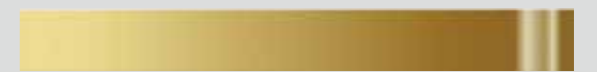

DZ-F08

# Floor Series



DZ-DB01



DZ-DB02



DZ-DB03



DZ-DB04



DZ-DB05



DZ-DB06



DZ-DB07



DZ-DB08



DZ-DB09



DZ-DB10



DZ-DB11



DZ-DB12

# Smart Platform Lift



DZ-PE01

DZ-PE02

DZ-PE03

DZ-PE04



DZ-PE05

DZ-PE06

DZ-PE07

# Ceiling Series/Floor Series



DZ-PE05  
Surface light

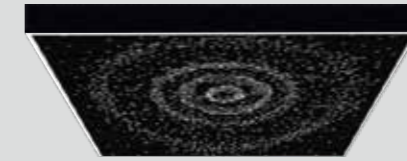

DZ-PE06  
Milky Way



DZ-PE07  
Starry sky



DZ-PE07  
Woven carpet



DZ-PE08  
High-end rock board

# Car Operation Panel



**BUTTON CALL BOX:**  
Model: DZ36F  
Material: stainless steel + acrylic

**CALL BOX**  
Model: DZ33-A  
Display: 5.25inch touch screen  
Button: touch button  
Panel: glass

**COP**  
Model: DZ33-A/B  
Display: 13.25inch / 17.45inch touch screen  
Button: Touch button  
Panel: Glass







**COP**

Model: DZ31-A

Display: 5.64inch LED segment display

Button: mechanical button

Panel: stainless steel + acrylic

Basic parameters/component name		Parameters		Note
1	Model/Series	PT1000-L	PT1000-H	
2	Maximum load kg	≤320kg	≤320kg	
3	Rated speed m/s	≤0.3m/s	≤0.3m/s	
4	Number of floors	≤5	≤5	
5	Lifting height m	≤12	≤12	
6	Platform background height mm	2100	2100	
7	Door opening height mm	2000	2000	
8	Counterweight position	Rear mounted/Lateral	Rear mounted/Lateral	
9	Minimum top floor mm	2500	2500	
10	Minimum bottom pit mm	60	60	
11	Traction ratio	1	1	
12	Car frame platform	Backpack rack	Backpack rack	
<b>Car Configuration</b>				
14	Car wall			
15	Floor			
<b>Core Power</b>				
19	Rated power kW	1KW	●	●
20	Voltage	AC220V	●	●
21	Brake voltage	DC110V	●	●
22	Rotary encoder	ERN 1387	●	●
<b>Intelligent Control</b>				
24	Control cabinet model	iCtrl-PRO vertical model	●	●
25		iCtrl-PRO horizontal model	○	○
26	Chip	32-bit	●	●
27	Driver power	3.7kw	●	●
28	Communication method	CAN communication	●	●
29	Input power	220V	●	●
30	Appearance kit	Powder spray	●	●

31	<b>Guidance system</b>			
32	Hoisting rope	Steel belt	●	●
33	Car guide rail	T78	●	●
34	Counterweight guide rail	Aluminum Alloy 6063-T5	●	●
35	Guide shoe	Flat side rolling guide shoe	●	●
36	<b>Door opening method</b>			
37	Automatic double doors		●	●
38	Automatic single opening door		○	○
39	<b>signal system</b>			
40	In-car control box	XCP31	●	○
41		10.1-inch touch screen	○	●
42		13.3-inch touch screen	○	○
43	Out-hall call	Single button	●	●
44	Leveling system	Absolute position	●	●
45	<b>Safety components</b>			
46	Safety clamp	FSGS10E electronic safety clamp	●	●
47	Buffer	Polyurethane HC-B-3	●	●
48		Safety touch panel + torque feedback	●	/
49	Door protection (light curtain)	Light curtain	/	●
50	<b>Smart functions</b>			
51	Torque limit		●	●
52	PG vector control		●	●
53	Terminal floor protection		●	●
54	Speed feedback detection function		●	●
55	STO feedback detection function		●	●
56	Drive overheat self-detection		●	●
57	Energy saving mode		●	●
58	Current ramp removal		●	●
59	Maintenance carrier reduction		●	●
60	Door lock short circuit detection		●	●
61	Integrated ARD function		●	●
62	STO		●	●
63	Release function		●	●
64	<b>One-button emergency call</b>		●	●
65	<b>Absolute position system</b>		●	●
66	<b>Remote IoT</b>			
67	Voice help, real-time call		○	○
68	Over-the-air upgrade of the entire elevator		○	○
69	Remote fault query		○	○
70	Real-time monitoring of elevator status		○	○
71	Real-time notification of elevator faults		○	○
72	<b>Hoistway components</b>			
73	Backpack rack		●	●
74	Travel cable		●	●
75	Guide rail bracket		●	●
76	Counterweight system		●	●
77	Electrical accessories		●	●
78	Aluminum alloy shaft	White	●	●
79		Champagne gold	○	○
80		Black	○	○
81	Shaft glass	White glass	●	●
82		Gray glass	○	○
83	<b>Mechanical accessories appearance color</b>			
84	White		●	●
85	Rose gold		○	○
86	Black		○	○
87	<b>Note: The above configuration parameters may change over time without further notice. The final order configuration is subject to the order.</b> ● is standard configuration, ○ is optional			

# Small Machine Room Passenger Elevator Construction

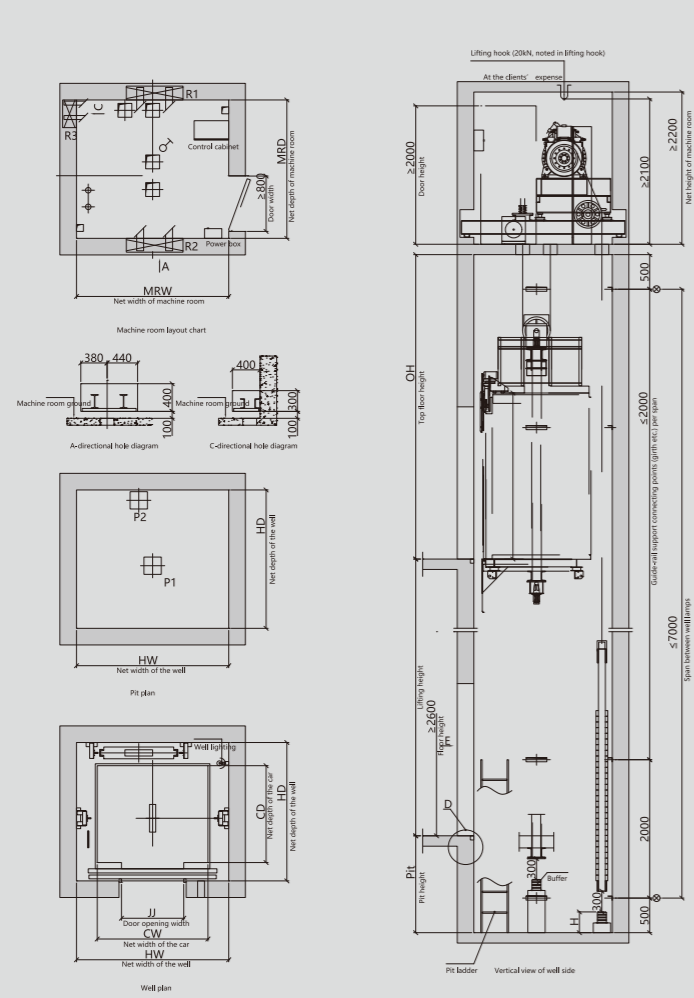

Model	Load KG	Passenger NO.	speed m/s	(mm) Car specification CWxCD	(mm) Door opening size JJxOPH	(mm) Well size HWxHD	(mm) Machine room size MRWxMRD	(mm) Pit depth Pit	(mm) Top floor height OH	Power	Acting force				
											R1	R2	R3	P1	P2
450/L0	450	6	1	1100x1100	700x2100	1700x1700	1700x1700	1400	4500	3.2	28800	17200	1900	44000	35000
450/L.5			1.5					4600	4.9						
630/L0	630	8	1	1400x1100	800x2100	2000x1700	2000x1700	1400	4500	4.3	35200	21800	4300	58000	45600
630/L.5			1.5					4600	6.4						
630/L.75			1.75					4700	7.5						
800/L0	800	10	1	1400x1350	800x2100	2000x2000	2000x2000	1400	4500	5.4	44800	27400	5400	72000	56000
800/L.5			1.5					4600	8.1						
800/L.75			1.75					4700	9.4						
1000/L0	1000	13	1	1600x1400	900x2100	2200x2000	2200x2000	1400	4500	6.7	53400	32200	6000	88000	68000
1000/L.5			1.5					4600	10						
1000/L.75			1.75					4700	11.7						
1150/L0	1150	15	1	1900x1400	1000x2100	2500x2100	2500x2100	1400	4600	7.8	55600	36300	7800	98000	75000
1150/L.5			1.5					4700	11.7						
1150/L.75			1.75					4800	13.6						
1250/L0	1250	16	1	1900x1500	1100x2100	2500x2200	2500x2200	1400	4600	8.5	60400	39400	8500	106000	81000
1250/L.5			1.5					4700	12.7						
1250/L.75			1.75					4800	14.9						
1350/L0	1350	18	1	1900x1600	1100x2100	2500x2300	2500x2300	1400	4600	9.2	67200	43400	8700	114000	87000
1350/L.5			1.5					4700	13.8						
1350/L.75			1.75					4800	16.1						
1600/L0	1600	21	1	2000x1750	1200x2100	2600x2450	2600x2450	1400	4600	11	73600	47600	9600	128000	96000
1600/L.5			1.5					4700	16.6						
1600/L.75			1.75					4800	19.4						

# Machine Roomless Passenger Elevator Construction

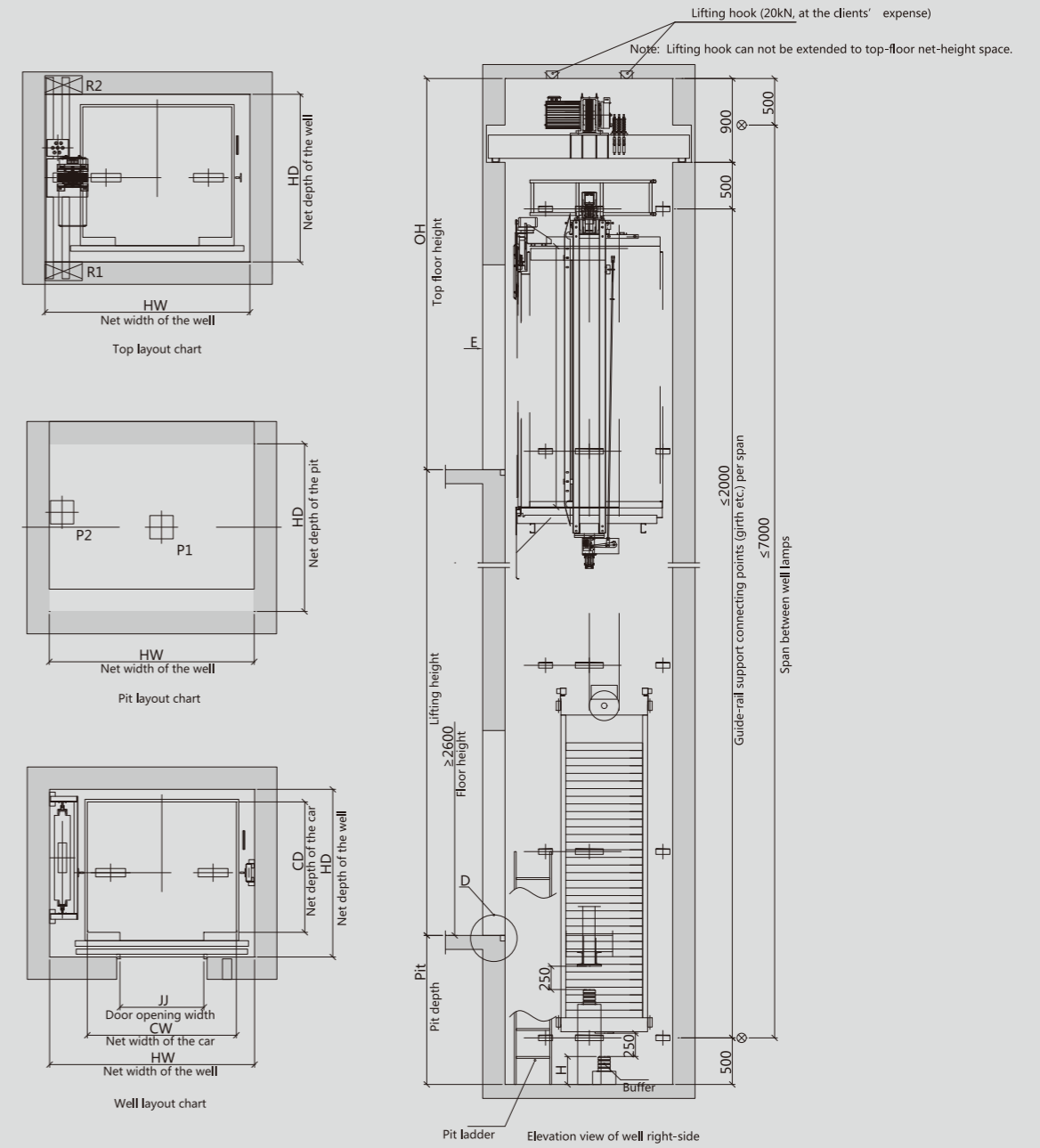

Model	Load KG	Passenger NO.	speed m/s	(mm) Car specification CWxCD	(mm) Door opening size JJxOPH	(mm) Well size HWxHD	(mm) Pit depth Pit	(mm) Top floor height OH	Power	Acting force			
										R1	R2	P1	P2
630/L0	630	8	1	1200x1350	800x2100	1950x1750	1500	4400	4.2	19800	26400	58000	45600
630/L.5			1.5				4500	6.4					
630/L.75			1.75				4600	7.4					
800/L0	800	10	1	1400x1350	800x2100	2050x1750	1500	4600	5.4	25700	27100	72800	56000
800/L.5			1.5				4700	8.1					
800/L.75			1.75				4800	9.4					
1000/L0	1000	13	1	1600x1400	900x2100	2250x1800	1500	4600	6.7	27400	39600	88000	68000
1000/L.5			1.5				4700	10.1					
1000/L.75			1.75				4800	11.8					

# Perfect Function

## Standard Function

VVVF drive	Motor rotating speed can be precisely adjusted to get smooth speed curve in lift start, travel and stop and gain the sound comfort.
VVVF door operator	Motor rotating speed can be precisely adjusted to get the more gentle and sensitive door machine start / stop.
Independent running	The lift can not respond to outer calling, but only respond to the command inside the car through the action switch.
Automatic pass without stop	When the car is crowded with the passengers or the load is closeto preset value, the car will automatically pass the calling landing in order to keep maximum travel efficiency.
Automatically adjust door opening time	Door-open time can be automatically adjusted according to the difference between landing calling or car calling.
Reopen with hall call	In the door shutting process, press reopen with hall call button can restart the door.
Express door closing	When the lift stops and opens the door, press door-shut button, the door will be closed immediately.
Car stops and door open	The lift decelerates and levels, the door only opens after the lift comes to a complete stop.
Car arrival gong	Arrival tong in the car top announces that the passengers arrive.
Command register cancel	If you press the wrong floor command button in the car, twice continuous pressing of same button can cancel the registerec command.
Photocell protection	In the door open and shut period, infrared light that covers the whole door height is used to probe the door protection device of both the passengers and objects.
Designated stop	If the lift can not open the door in the destination floor out of some reason, the lift will close the door and travel to the next designated floor.
Overload holding stop	When the car is overload, the buzzer rings and stops the lift in the same floor.
Anti-stall timer protection	The lift stops operation due to slippery traction wire rope.
Start protection control	If the lift does not leave door zone within the designated time after it gets started, it will stop the operation.
Inspection operation	When the lift enters into inspection operation, the car travels at inching running.
Fault self-diagnosis	The controller can record 62 latest troubles so as to quickly remove the trouble and restore the lift operation.
Repeated door closing	If the lift can not close the door due to certain obstacle or interference, the lift will reopen or re- shut the door until sundries are eliminated.
Up/down over-run and final limitprotection	The device can effectively prevent from the lift' s surging to the top or knocking the bottom when it is out of the control. It results in the more safe and reliable lift travel.
Down over- speed protection device	When the lift downs 1.2 times higher than the rated speed, this device will automatically cut off control mains, stop the motor running so as to stop lift down at over-speed. If the lift continues to down at over- speed, and the speed is 1.4 times higher than rated speed, safety tongs act to force the lift stop in order to ensure the safety.
Upward over-speed protection device	When the lift ups 1.2 times higher than rated speed, the device will automatically decelerate or brake the lift.
Micro-touch button for car call and hall call	Novel micro-touch button is used for operation panel command button in the car and landing calling button.
Floor and direction indicator inside car	The car shows the lift floor location and current travel direction.
Floor and direction indicator	The landing shows the lift floor location and current travel direction.
Emergency car lighting	Emergency car lighting automatically activated once power failure.
Inching running	When the lift enters into emergency electric operation, the car travels at low speed inching running.

Five way intercom	Communication amid car, car top, lift machine room, well pit and rescue duty room through walkie-talkie.
Bell	In emergency conditions, if bell button above car operation panel is continuously pressed, electric bell rings on top of the car.
Fire emergency return	If you start key switch in main landing or monitor screen, all the callings will be cancelled. The lift directly and immediately drives to the designated rescue landing and automatically opens the door.
Car vniation, light automatic shut off	If there is no cling or command signal within the stipulated time, the car fan and lighting will be automatically closed in order to save the energy.
Remote shut-off	The lift can be called to main landing (after finishing the service) through the key switch and automatically exists the service.

## Optional Function

Leveling when power failure	In normal power failure, the chargeable battery supplies the lift power. The lift drives to the nearest landing.
Anti- nuisance	In the light lift load, when three more commands appear, in order to avoid the unnecessary parking, all the registered callings in the car will be cancelled.
Open the door in advance	When the lift decelerates and enters into door open zone, it automatically opens the door to enhance the travel efficiency.
Direct parking	It completely accords with distance principle with no crawling in the leveling. It greatly enhances the travel efficiency.
Group control function	When three or more same model lift groups are controlled in use, the lift group can automatically choose the most appropriate response. It avoids the repeated lift parking, reduces the passengers' waiting time and increases the travel efficiency.
Duplex control	Two sets of same model lifts can unanimously respond the calling signal through the computer dispatch. In this way, it reduces the passengers' waiting time to the greatest extent and enhances the travel efficiency as well.
On-duty peak service	Within the preset on- duty time, upward transport from the home landing is extremely busy. The lifts are continuously dispatched to the home landing in order to satisfy on-duty peak service.
Off-duty peak service	Within the preset off-duty period, the lifts are continuously dispatched to top floor in order to satisfy off-duty peak service.
Door open time extending	Press special button in the car, the lift door keeps open for certain period of time.
Voice announcer	When the lift normaly arrives, voice announcer informs the passengers about the relevant information
Car assistant operatin box	It is used in the large loading weight lifts or the lifts with crowded passengers so that more and more passengers can use the car.
Operation box for the handicapped	It is convenient for the wheelchair passengers and those who have vision problems.
Intelligent alling service	The car command or hoist-way calling can be locked or connected through special Intelligent Input.
IC card control function	All (partial) landings can only input car commands through IC Card after the authorization.
Remote monitor	The lift long-distance monitor and control can be fulfilled through modem and telephone. It is convenient for the factories and service units to timely know the travel conditions of every lift and promptly take the corresponding measures.
Remote control	The lift can have independent travel according to the specific requirements through operation monitor screen (optional).
Camera function in the car	The camera is installed in the car to monitor the car conditions.

# Escalator, Fashionable, Aesthetic And Swift

DAZEN escalator has integrated with domestic and foreign advanced technologies to constantly pursue the improvement in technique and perfect in detail. Meanwhile it combines the safety, practicability, durability and visual aesthetics to bring more comfortable and convenient experience for people.

## It is natural and artistic with comfortable designs

The escalator adopts streamlined design, making it natural in appearance. Beautiful and fashion, the escalator can be well integrated in the surrounding architectural environment.

## It is durable in use and favorable in performance

Adopting the most advanced domestic and foreign manufacturing techniques, its designed in large truss. The rigidity and anti-distortion can reach inter national level.

## Stable and reliable, it is safety-oriented

Secured by system of microcomputer, it is equipped with a series of extended functions, not only ensuring the continuous highly-efficient and stable operation of the escalator, but also able to rapidly respond to emergency situations.



# Moving Walk, Reliable Ceaseless Operation

DAZEN moving walk adopts humanized design, introducing advanced techniques into aspects of the product to provide perfect large passenger flow solutions for various public apaces, In urban public spaces, it can provide conveniences for people.

## The humanized design provides comfortable experiences

In different environments, it can be allocated with different accessories to improve user experience to the maximum extent. The humanized design can satisfy the different demands for clients to bring comfortable and stable user experience.

## It is environmental protective with energy-saving operation

It can choose variable frequency driving technology optional to effectively avoid interferences from other factors and further improve the energy-saving effect and reduce the operation cost to the maximum extent experience.

## It is safe, stable and durable

The highly-precise metal truss structure makes it tight, secure and safe with strong carrying capacity. With advanced techniques, it insists on details to make sure the product quality in each link from production to application.

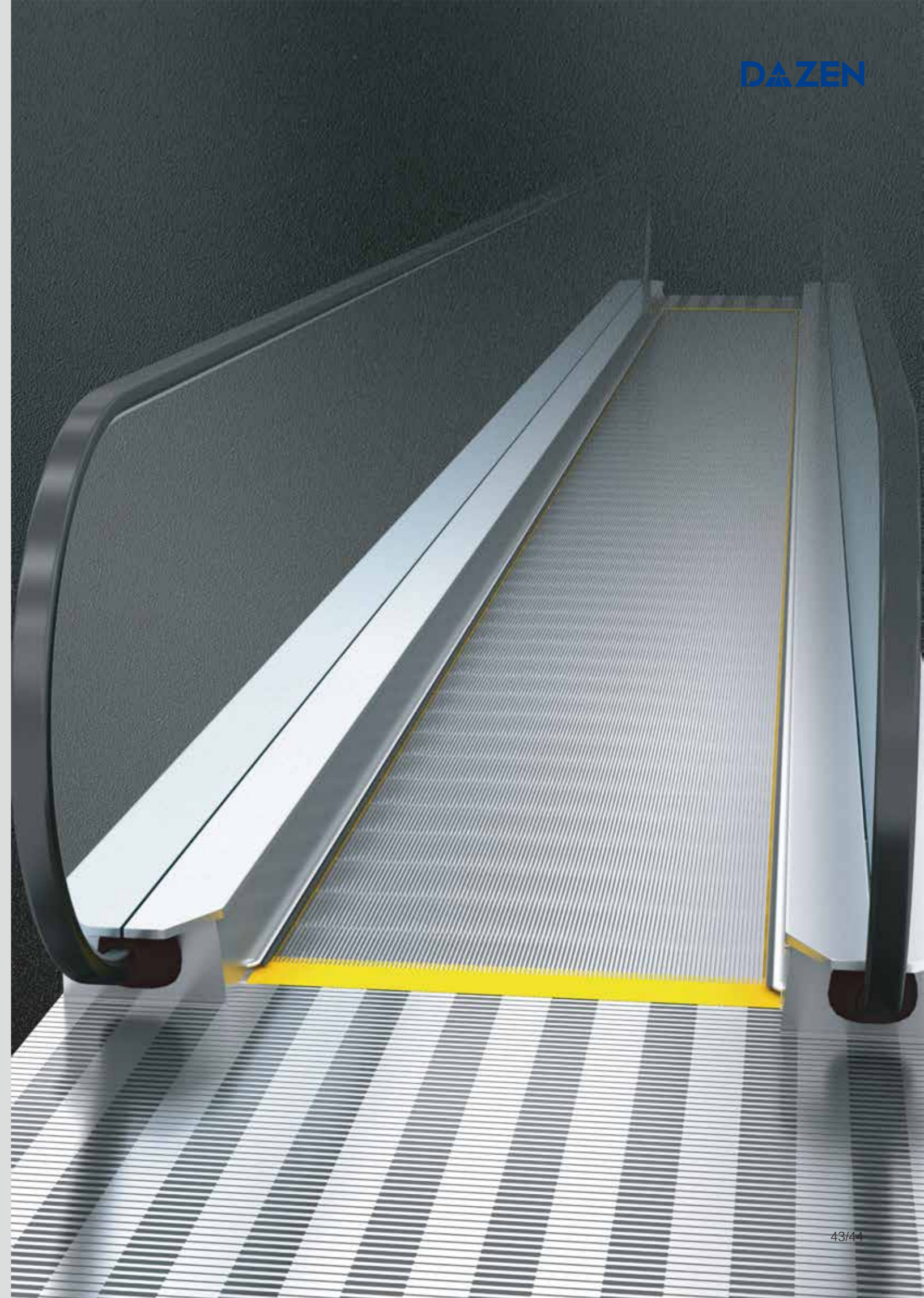

# Function Configuration

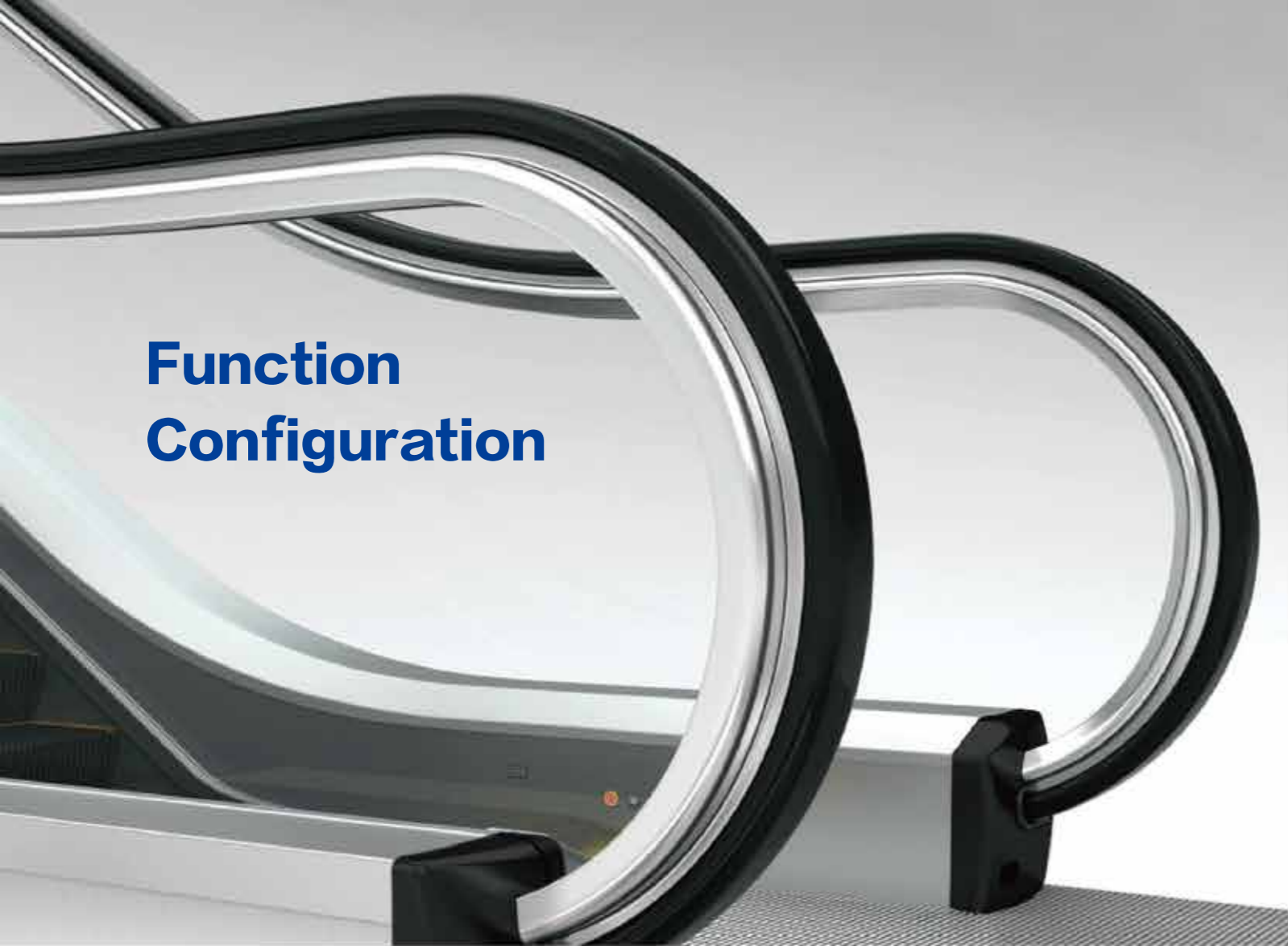

## Handrail Lighting



White(Optional)



Yellow(Optional)

## Running Direction Indicator



Transparent plastic LED display (Optional)



Black plastic dot matrix display (Optional)

## Skirt Lighting



White(Optional)



Red(Optional)

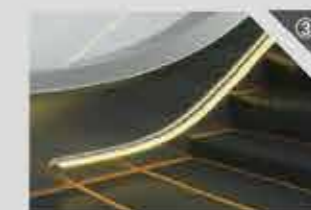

Yellow(Optional)

## Combs

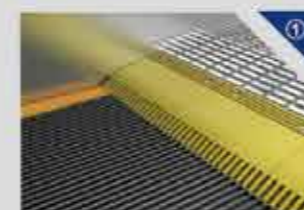

Yellow polyester(Standard)



Aluminum(Optional)

## Inner and Outer Decking



Hairline stainless steel(Standard)



Aluminum alloy(Optional)

## Balustrade Design

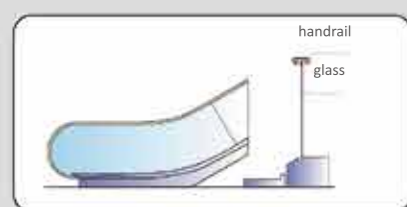

Type-I(Slim)

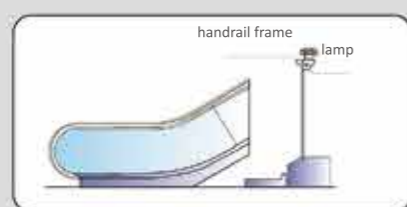

Type-P(Normal),w.Lighting(Inclined)

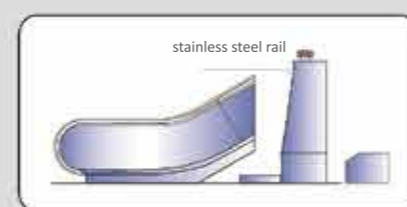

Type-T(Inclined)

## Step



Black stainless steel with yellow alert(Standard Room)



Aluminum with Security Cordon (Optional)

## Pallet

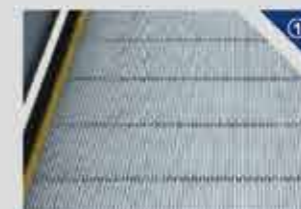

Aluminum alloy with the yellow line(Standard)



Black stainless steel with yellow warning line(Optional)

## Handrail Color



Black(Standard)



Grey(Optional)



Red(Optional)



Yellow(Optional)

Note: Pictures might be slightly different from actual colors. Please take real product as criterion.

## Front Panel

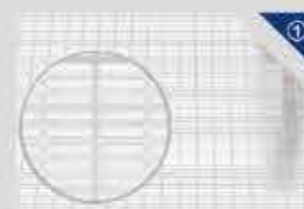

Square groove black painting (Standard)



Black coating in the slot of the box (Optional)



Striped groove black paint (Optional)



### 30° Escalator Construction Parameters

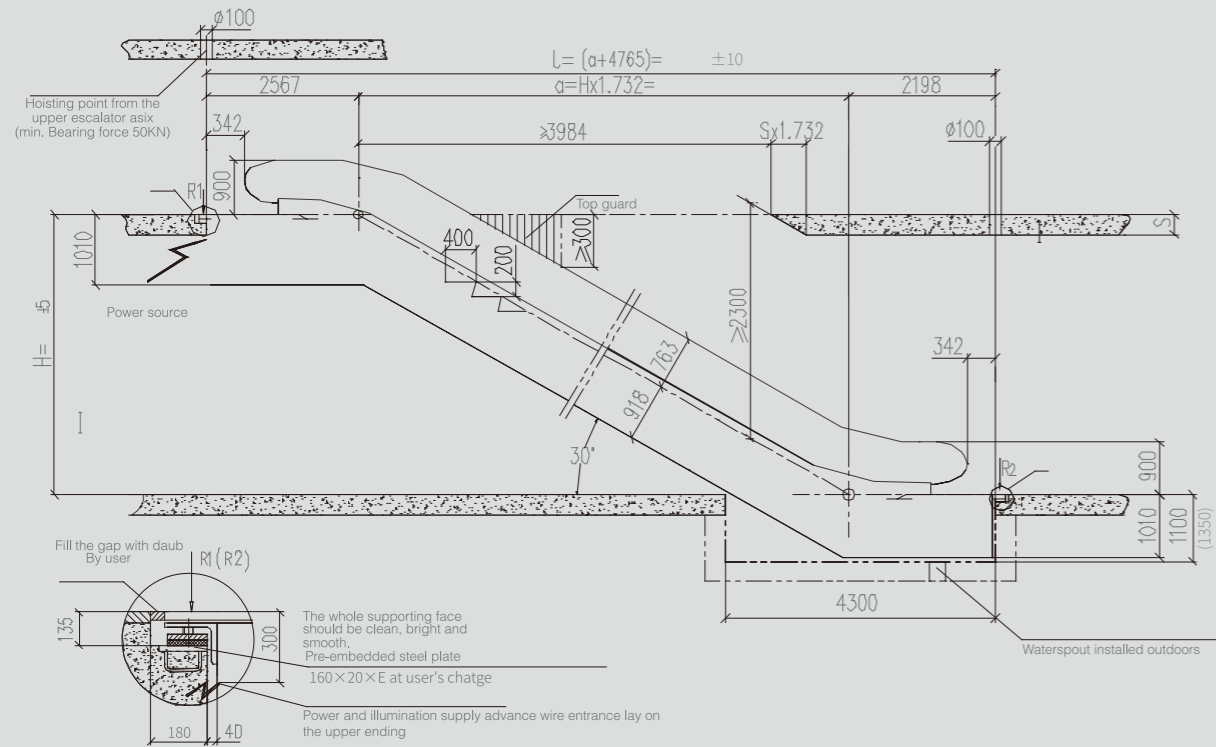

(mm)	A	B	C	D	E	F
1000	1000	1158	1238	1600	1660	2310
800	800	958	1038	1400	1460	2110
600	600	758	838	1200	1260	1910

Model	Travelling height (mm)	Net height (KN)	Supporting		Motor power (Kw)	Transport size	
			R1 (KN)	R2 (KN)		h	l
F600 (600-30°) (3600人/h) 0.5m/s speed 0.5m/s	3000	57	46	41	7.5	2750	10900
	3500	60	49	44		2780	11890
	4000	64	52	47		2810	12880
	4500	68	56	50		2830	13870
	5000	71	59	53		2840	14860
	5500	75	62	56		2860	15860
F800 (800-30°) (4800人/h) 0.5m/s speed 0.5m/s	3000	59	52	47	7.5	2750	10900
	3500	63	56	50		2780	11890
	4000	67	60	54		2810	12880
	4500	71	64	57		2830	13870
	5000	74	68	60		2840	14860
	5500	82	74	66		2860	15860
F1000 (1000-30°) (6000人/h) 0.5m/s speed 0.5m/s	3000	63	59	53	7.5	2750	10900
	3500	67	64	57		2780	11890
	4000	71	68	61		2810	12880
	4500	75	73	65		2830	13870
	5000	83	79	71		2840	14860
	5500	87	84	75		2860	15860
	6000	92	88	79	11	2870	16860

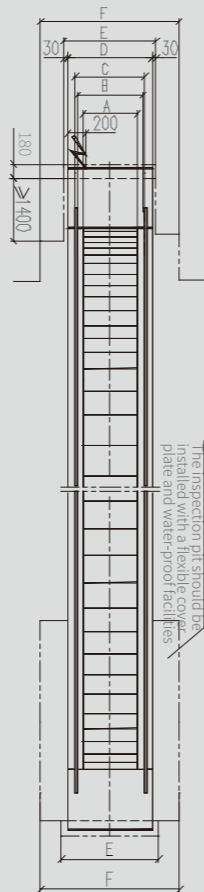

### 0° Moving Walk Construction Parameters

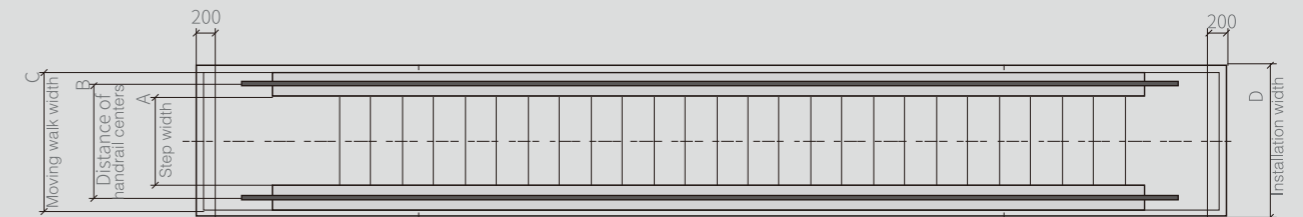
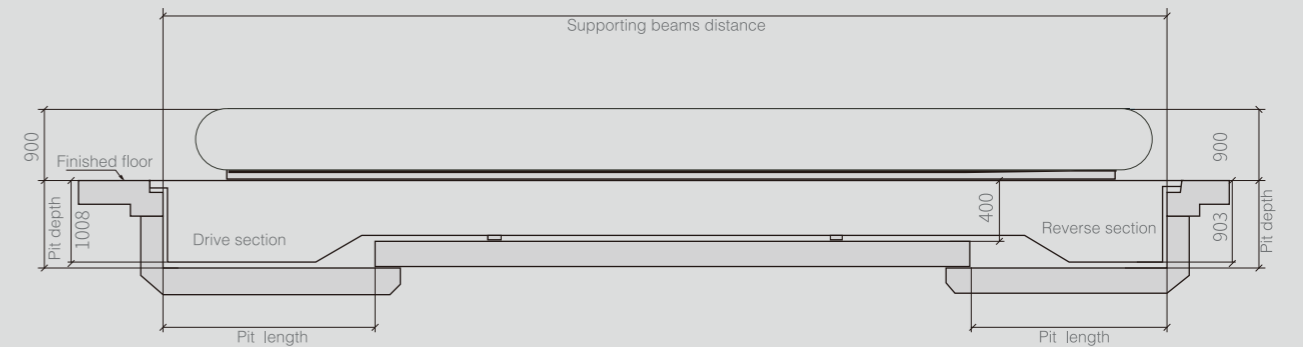

Model	L Section height (mm)	Rated speed (m/s)	Rated load capacity (人/h)	Inclination (°)	Motor power (kw)	A (mm)	B (mm)	C (mm)	D (mm)
E800 (800/0°-6°)	4100	0.5	4800	0-6	7.5	800	1038	1400	≥1460
E1000 (1000/0°-6°)	4100	0.5	6000	0-6	7.5	1000	1238	1600	≥1660

# Project Case



Chengdu Sheraton Hotel



Yunzhong Paradise



Asia Pacific International Hotel



Jiakai City Building



Zhongyin Huilong



Westin Hotel



Oriental Plaza



Hefei Santiago



Luoyang Chamber Of Commerce Building



Beijing Asia Hotel



Changchun Golf Business Hotel



Helen Bay



Indonesia



Philippines



Indonesia



Indonesia



Kosovo



Georgia



Georgia



Georgia



Georgia



England



Tunisia



Grenada



Kyrgyzstan



Philippines



Côte D'ivoire

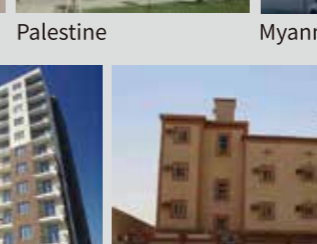

Palestine

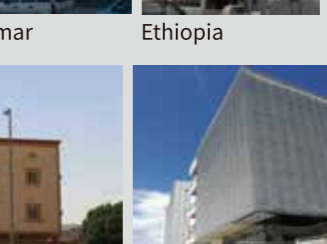

Myanmar

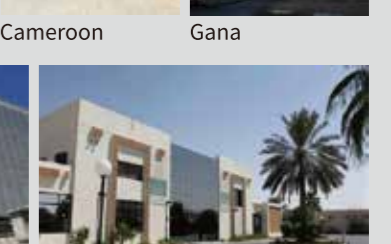

Ethiopia



Cameroon



Gana



Qatar

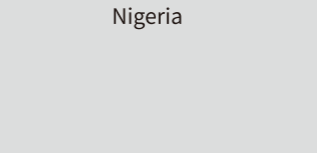

Uae

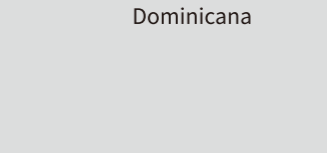

Nigeria

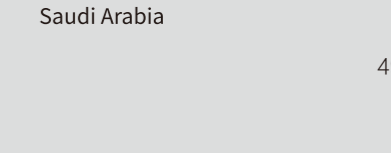

Dominicana

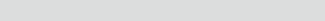

Saudi Arabia